

Problem set 3

This sheet is two sided. Wednesday pairs please hand in to my pigeonhole by Wednesday 10am, Friday pairs by Thursday 1pm. Clearly explain your reasoning.

1 *Estimation*

- Estimate how thick a layer of rubber is deposited on the road by a car tyre. Comment on your result.
- Estimate the world-record speed for cycling and for swimming. (Hint: First estimate how much mechanical power an athlete can put out.)

2 *Scales (again)*

You stand on a scale holding a book (for simplicity of diagramming, you balance it on your head). You then place the book next to you on the scale. The two scale readings are of course identical. Of course!? Prove the equality by using Newton's laws and drawing free-body diagrams. The givens here are your weight and the book's weight. You are in effect asked to prove that the weight of the combined you–book object is the sum of the individual weights.

Draw *well-separated* free-body diagrams. Clearly label the third-law pairs (pairs that must be equal and opposite as a consequence of Newton's third law); carefully distinguish uses of Newton's second law from Newton's third law; and describe each force in words. Ensure that your argument convinces a skeptical reader (perhaps try it on your supervision partner), one who says at every opportunity 'Why are those forces equal in magnitude?', 'Are you sure it isn't Newton's third law that justifies this step?', 'Or maybe it should be Newton's second law here?', and so on.

3 *Sking*

You (tall rectangle, with mass m) stand on a wedge sliding down a frictionless plane, as shown in the figure. What weight does the scale (shaded rectangle) read? Use clearly labeled, well-separated free-body diagrams.

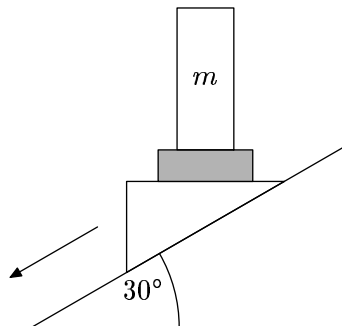

4 *Analogy*

Into how many regions can n planes divide space? Find the maximum number (what conditions on the planes ensure that the number is a maximum?). For example, one plane divides space into two regions; two planes divide space into at most four regions (but only three if you are unlucky, and only two if you are really unlucky). Hint: Play with the one- and two-dimensional versions of this problem, and then try to generalize the patterns that you find.

5 *Virtual work*

The mass m_1 slides down the plane with constant velocity, and m_2 rises with constant velocity (see the figure). Use the principle of virtual work to find the mass ratio m_1/m_2 . We live as usual in the make-believe world of physics: The plane is frictionless, the string is massless, and the pulley is massless and frictionless.

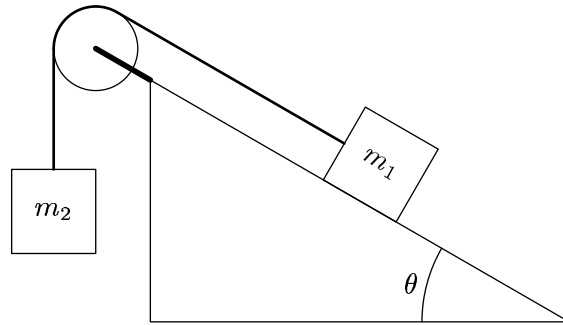

6 *Bouncing ball*

You drop a steel ball from a height of one or two metres. It lands on a scale and bounces up to nearly the original height. (Neglect air resistance.) Draw free-body diagrams for the ball at four times: (1) whilst you are holding it, (2) whilst it is falling, (3) when it is motionless on the scale (namely, just as it starts its upwards journey), and (4) whilst it is rising. Indicate qualitatively the relative magnitudes of the forces. Sketch qualitatively the scale reading as a function of time, whilst the ball is on the scale.